

## Features

- Fully assembled Pick & Place unit with all mounting components — ready to install, plumb and run.
- Components have optional sensing capabilities. (see page 143)
- Made from our standard proven precision Tuff-Series linear actuators.
- We can supply a gripper mounting plate or make a custom one for any end-effector.

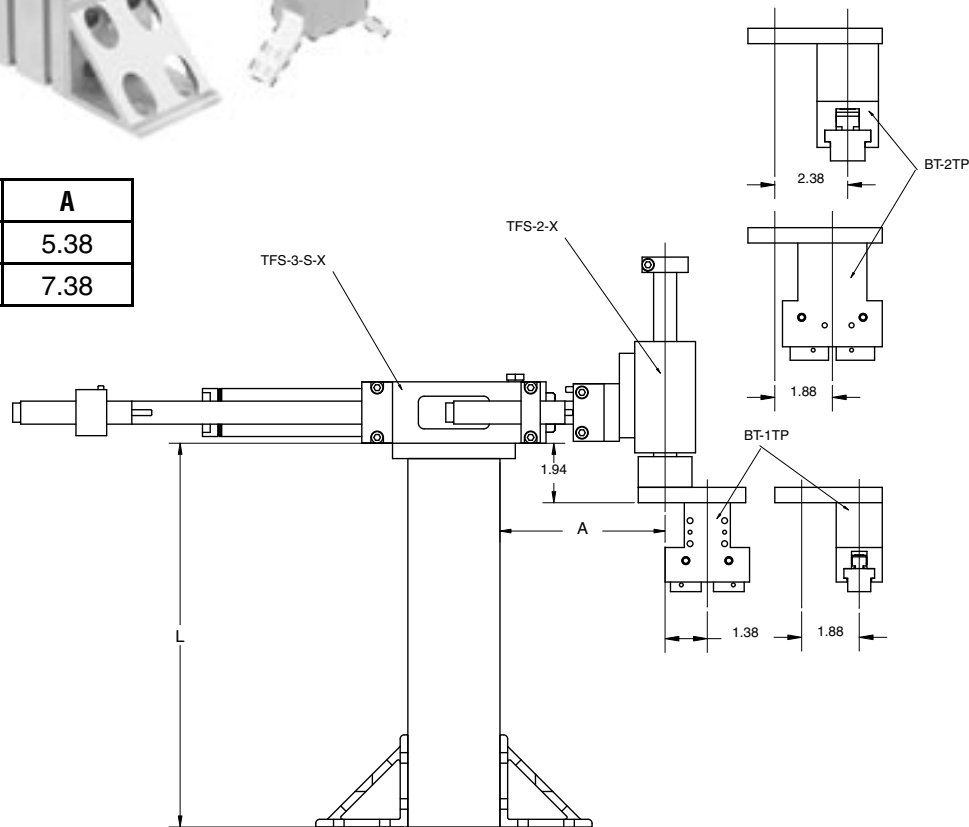

	A
TFS-3-S	5.38
TFS-3-L	7.38



## Ordering

The CMU-TFTF32 comes in several standard combinations. It includes stand, TFS-3, TFS-2, adapter plates, and optional gripper mounting plate, and can be ordered with the following number:

**CMU-TFTF32** - [ ] - [ ] - [ ] - [ ]

<p>TFS-3 Stroke &amp; Body 2" to 24" S or L – Short or Long Body Style</p>	<p>TFS-2 SIZE 10 (1.0" STROKE) 20 (2.0" STROKE) 30 (3.0" STROKE) 40 (4.0" STROKE)</p>	<p>EX-3 HEIGHT (L) 6 THRU 18 INCHES</p>	<p>GRIPPER ADAPTER N - No plate 1 – Adapt to BT-1 series gripper 2 – Adapt to BT-2 series gripper</p>
--	---	---	---

## Technical Data

TFS -3	= 1 1/2" BORE
TFS -2	= 1 1/8" BORE
AIR CONNECTION	= 1/8 NPT
AIR PRESSURE	= 60 – 110 PSI
RECOMMENDED LOAD	= 35 lbs.

P