

Features

- Fully assembled Pick & Place unit with all mounting components — ready to install, plumb and run.
- Components have optional sensing capabilities. (see page 143)
- Made from our standard proven precision Tuff-Series linear actuators.
- We can supply a gripper mounting plate or make a custom one for any end-effector.

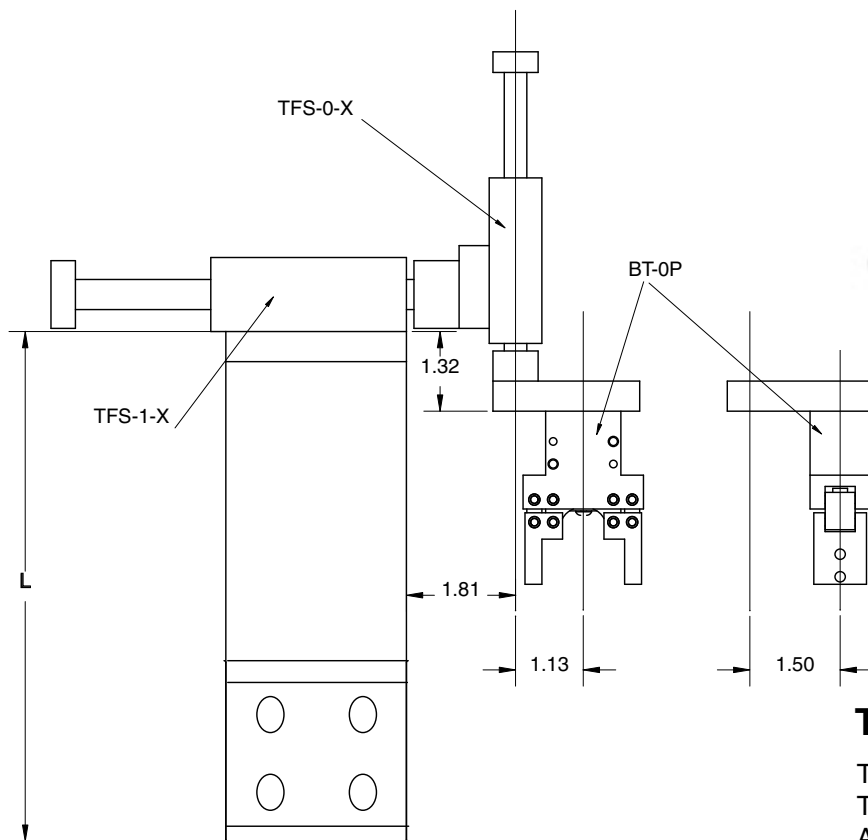

Technical Data

TFS -1	= 3/4" BORE
TFS -0	= 1/2" BORE
AIR CONNECTION	= 10-32
AIR PRESSURE	= 60 – 110 PSI
RECOMMENDED LOAD	= 3 lbs.

Ordering

The CMU-TFTF10 comes in several standard combinations. It includes stand, TFS-1, TFS-0, adapter plates, and optional gripper mounting plate, and can be ordered with the following number:

