

Features

- Fully assembled Pick & Place unit with all mounting components — ready to install, plumb and run.
- Components come with our stopscrew system for accurate stroke adjustment and optional sensing capabilities. (see page 143)
- Made from our standard proven precision components including our Tuff-Series line of linear actuators.
- We can supply a gripper mounting plate or make a custom one for any end-effector.

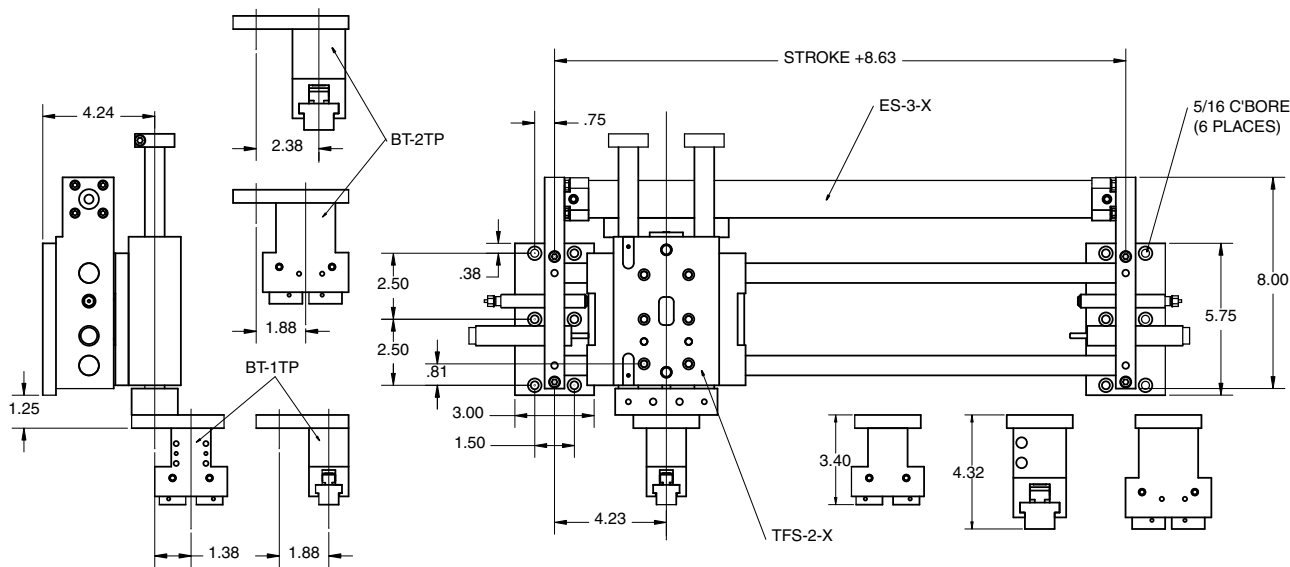
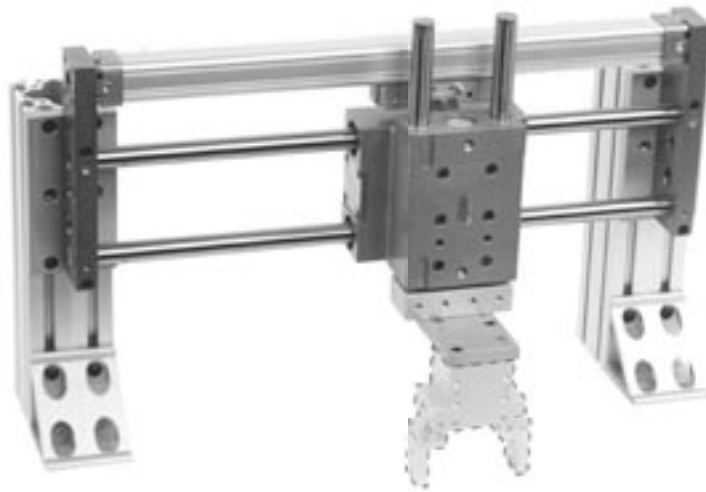

P

Ordering

The CMU-ESTF32 includes a ES-3, TFS-2, adapter plate, and optional gripper mounting plate and can be ordered with the following number:

CMU-ESTF32 - - -

ES-3 SIZE
STROKE IN INCHES

TFS-2 SIZE
10 (1" STROKE)
20 (2" STROKE)
30 (3" STROKE)
40 (4" STROKE)

GRIPPER ADAPTER
N - NO ADAPTER
1 - BT-1 SERIES ADAPTER
2 - BT-2 SERIES ADAPTER

Technical Data

ES -3	= 1" BORE
TFS -2	= 1 1/8" BORE
AIR CONNECTION	= 1/8 NPT
AIR PRESSURE	= 60 - 110 PSI
RECOMMENDED LOAD	= 35 lbs.